



12 VOLT WIND TURBINE

VERSION 2.0

User's Manual

Congratulations on your Sunforce Products Purchase. This product is designed to the highest technical specifications and standards. It will supply years of maintenance free use. Please read these instructions thoroughly prior to installation, then store in a safe place for future reference. If at any time you are unclear about this product, or require further assistance please do not hesitate to contact our trained professionals operating the customer support line 1888-478-6435 or email to info@sunforceproducts.com

ACCESSORIES INCLUDED

Stop Switch: 50 amp DC stop switch. This is used to safely apply a brake to your turbine, during either periods of intense wind or general maintenance

Circuit Breaker: A “slow-blow” type circuit breaker (D.C.), which can be used to disconnect the battery..

Plastic Disks: Anti static plastic components, that will prolong the life span of the turbine protecting from weather corrosion and static build up.

Your Sunforce Wind Turbine is designed with your personal safety as the first priority. However, there are still some inherent dangers involved with any electrical and/or mechanical equipment.

Safety must be the primary concern as you plan the location, installation and operation of the turbine. Please read the following:

Important Safety Instructions

Please take the time to read through this manual prior to assembly.

- 1) Place this instruction manual in a safe place for reference.
- 2) Wait until a calm day to install or perform maintenance on your Turbine.
- 3) Listen to your Turbine should you hear any mechanical noise, maintenance may be required, please contact Sunforce Products Customer Service.
- 4) After installation re-adjust and tighten the screws and bolts.
- 5) Adhere to proper grounding techniques as established by the NEC.
- 6) Your Sunforce Wind Turbine must be installed in accordance with this manual and local and national building code. Incorrect installation may void your warranty.
- 7) Wind turbine blades spin at a potentially dangerous speed this must be respected. Never approach a turbine in motion.

Mechanical Hazard

Rotating blades present the most serious mechanical hazard. The rotor blades are made of very strong thermoplastic. At the tip, the blades may be moving at velocities over 15m/s. At this speed, the tip of a blade is nearly invisible and can cause serious injury. Under no circumstances should you install the turbine where a person could come in contact with moving rotor blades.

Electrical Hazard

The Sunforce Wind Turbine is equipped with sophisticated electronics designed to provide protection from electrical dangers. Please note that the inherent personal dangers from electrical current still exist, therefore caution should always be used when connecting this and other electrical devices.

Heat in a wiring system is often a result of too much current flowing through an undersized wire or through a bad connection.

Batteries can deliver a dangerous amount of current. If a short circuit occurs in the wiring from the batteries, a fire can result. In order to avoid this threat, a properly sized fuse or circuit breaker is required in the lines connecting to the battery.

PACKAGE CONTENTS

Compare the parts shown in the following figure to ensure that the contents of the box contain all necessary parts.

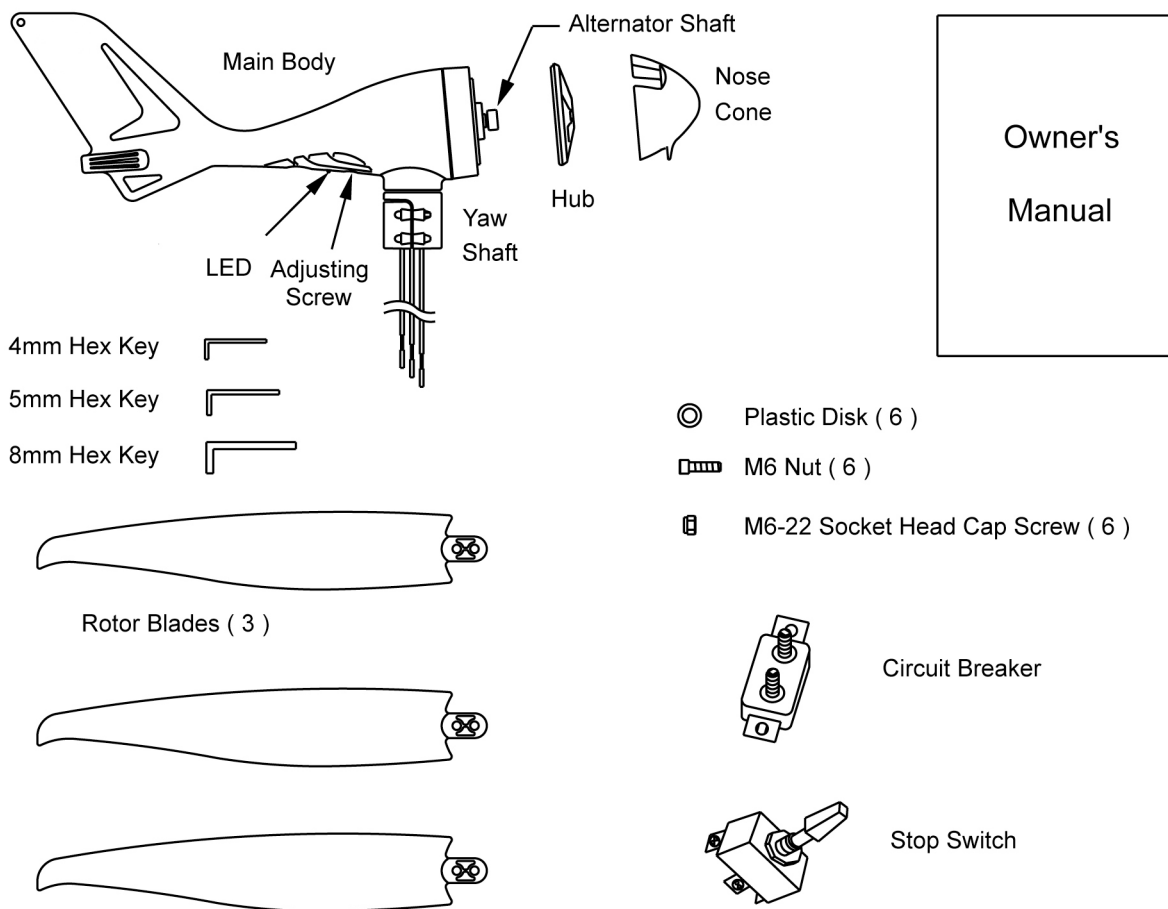

EXPLODED VIEW

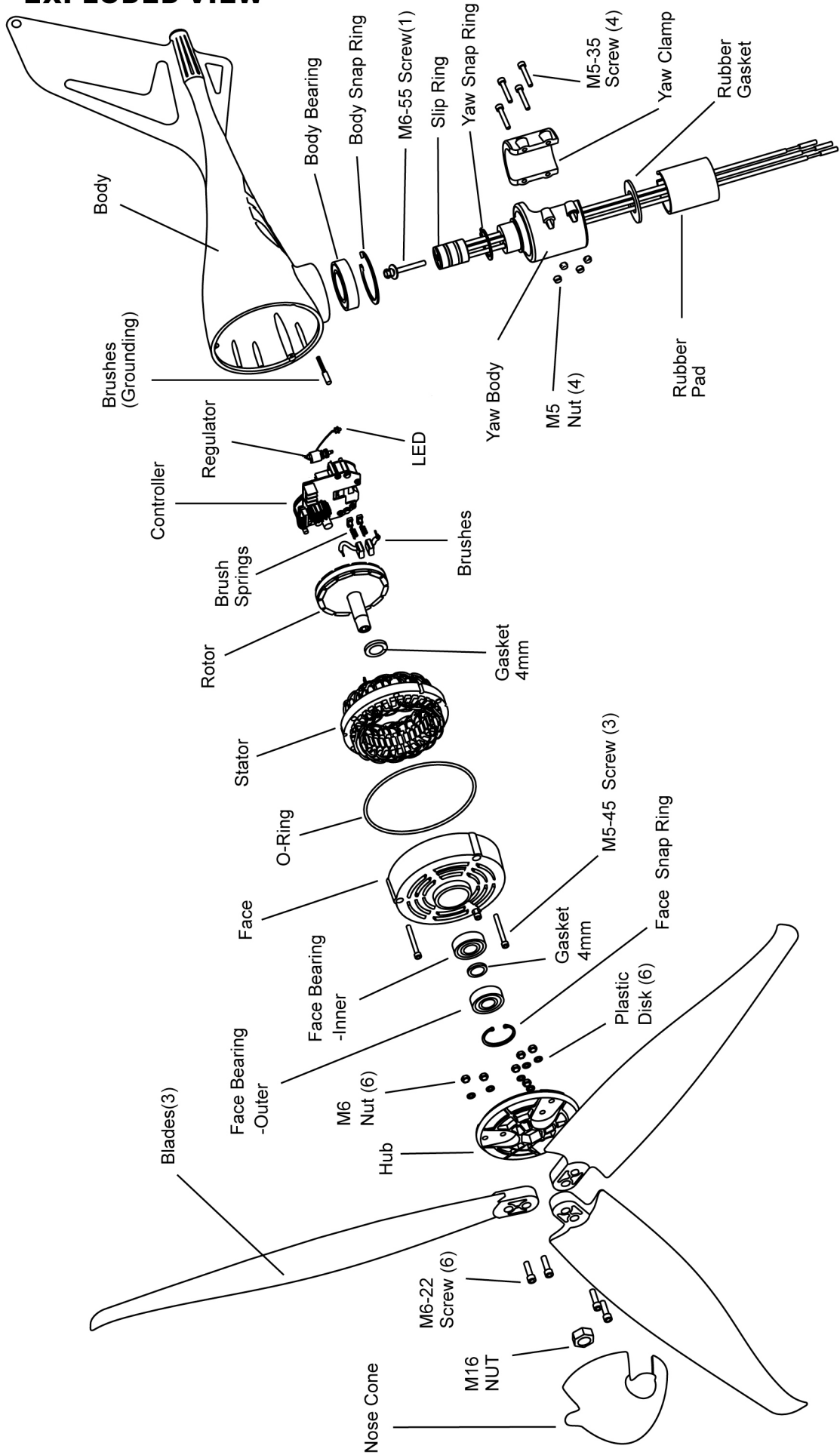

ELECTRICAL SYSTEM

SYSTEM WIRING DIAGRAMS

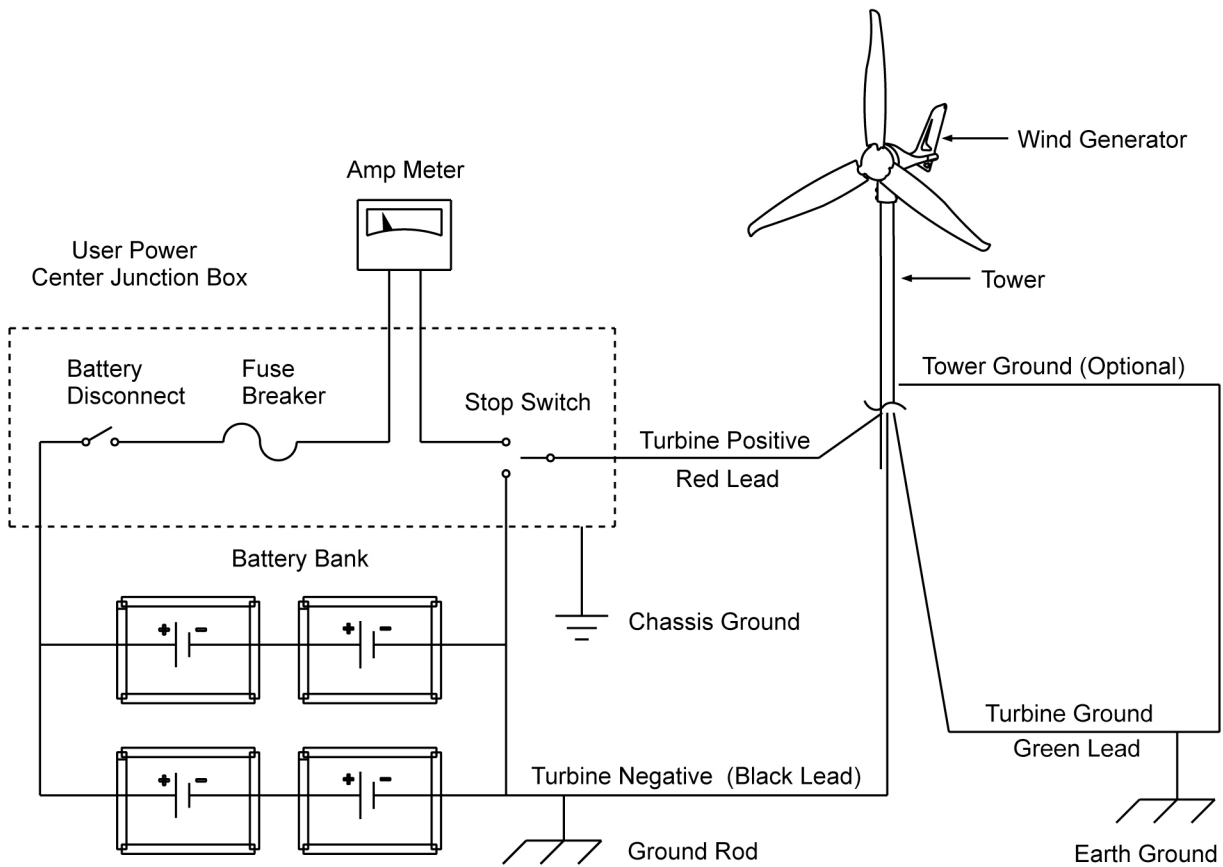

You can wire the Sunforce Wind Generator through most “power centers”. However, if you experience interference, you must bypass it and wire the Wind Generator directly to the battery bank and to its own set of battery posts. Allow the Wind Generator to operate independently and observe the charge rate and battery voltage.

Caution: Observe correct polarity throughout your system. Any reverse polarity can cause damage to both battery bank and wind turbine. This turbine is designed for 12 Volt systems only.

OVER-SPEED PROTECTION

Your Sunforce wind turbine has a built in protection that prevents possible damage in periods of extreme high winds. A brake is applied when the turbine senses 20 M/S or 45 MPH. At this point your turbine will stop spinning, the internal charging system will ‘cycle’ and wait for a drop in wind speed.

CIRCUIT BREAKER

Your Sunforce Wind Turbine includes a “slow-blow” type circuit breaker (Fuse). This circuit breaker should be placed between the stop switch and the batteries. The circuit breaker has two ‘poles’ one labeled BAT, this connects to the battery, one labeled AUX, this connects to the stop switch. (see diagram below)

Recommended Size for Slow-Blow Circuit Breaker

12-volt system: 25-30 amps D.C (included).

STOP SWITCH

Your Sunforce Wind Turbine includes a stop switch (50 amps D.C.), which can be used to “stop” the Wind Generator.

Diagram for Circuit Breaker and Stop Switch

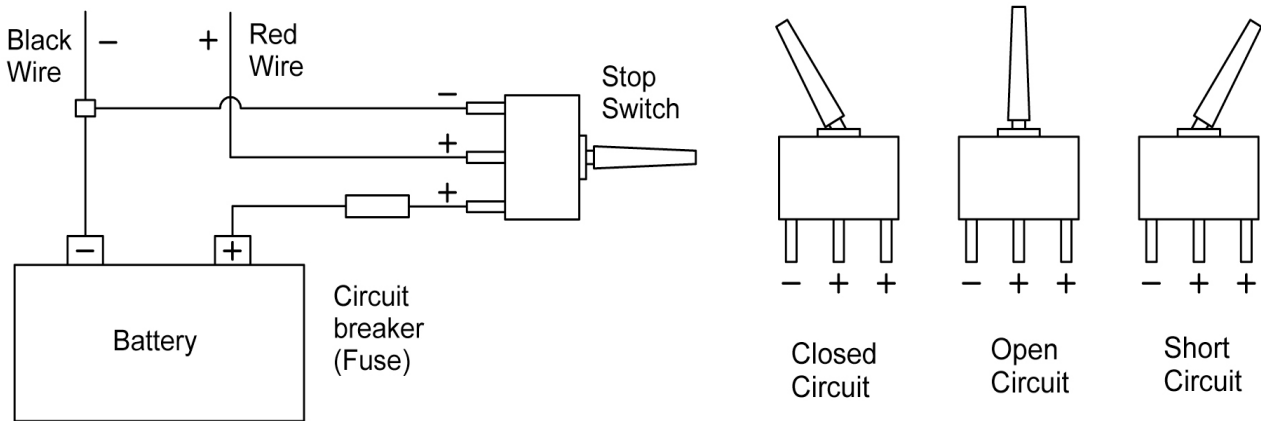

Caution: Prolonged periods of ‘open circuit ’ or ‘free-spin’ can cause excessive wear and tear on the turbine.

GROUNDING

Every wind turbine and turbine tower needs to be grounded at the tower base even though the system may be grounded at the battery bank. Grounding the tower at its base may help prevent shocks to persons touching the tower due to lightning or electrical faults. Please take the time to review the National Electrical Code (NEC) and local building and zoning regulations for complete requirements. Even in “Off Grid Systems” there are multiple ways for tower grounding, the most common method is a copper clad steel electrode(s) driven into the soil. Please view the following grounding diagram. Your Sunforce Wind Turbine has a GREEN ground line included for this purpose.

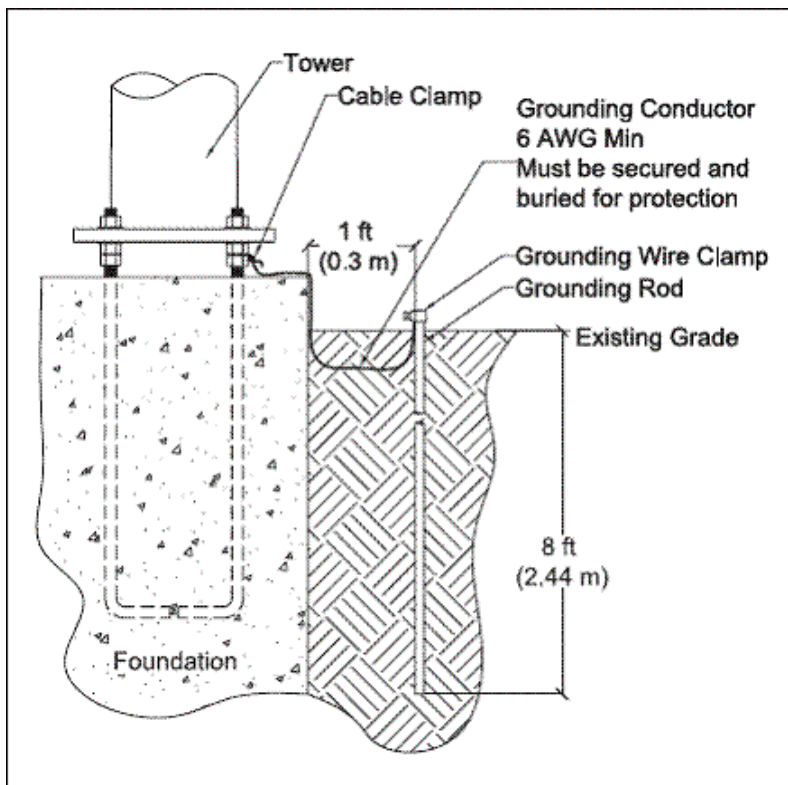

Example of grounding a wind turbine

VOLTAGE REGULATOR

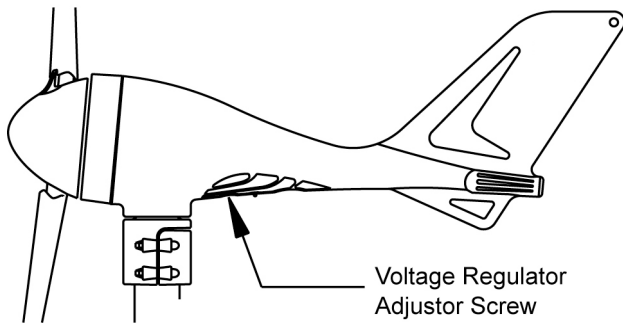

You can set the Sunforce Wind Generator's charging point by adjusting the voltage regulator (shown above). When the battery voltage reaches the regulator's set voltage, the Wind Generator will stop charging. Your Sunforce Wind Turbine will continually monitor the battery voltage. At this point the LED will 'blink'. Normal charging will resume when the battery voltage drops below the fully charged set point. At this point the LED will stop 'blinking' and operate as normal.

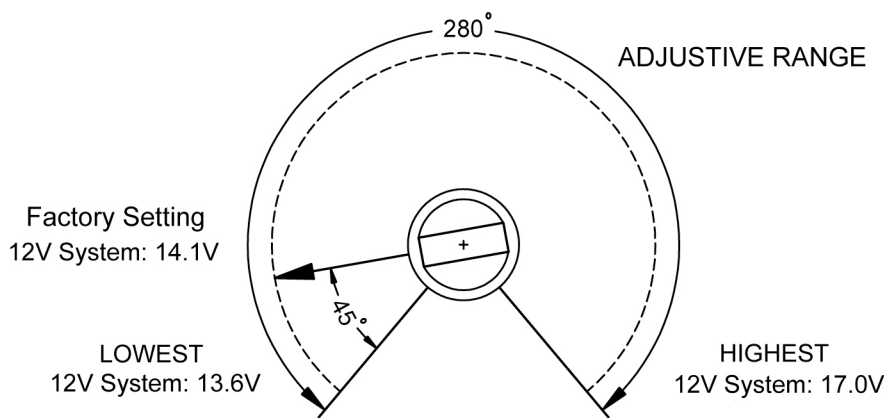

From the factory setting, rotate the adjusting screw 40 degree for each 0.48 volts change desired. For example, if you want to set your voltage regulator to 14.6 volts, turn the adjusting screw clockwise by 45 degree.

Voltage System	Stop Charging Point (Factory Setting)	Stop Charging Point Adjustable Range	Resume Charging Point (Factory Setting)
12V	14.1V	13.6V to 17.0V	12.6V

The adjusting screw will provide regulation settings for voltage ranges at least as wide as those shown above. The actual voltage set point at the extreme counter-clockwise position may be as much as 10% lower than the value listed, and at the extreme clockwise position may be up to 10% higher than the value listed.

CAUTION: Turning 'UP' the stop charging set point will not increase the Wind Generator's output voltage, amperage and power output and may result in damage to your battery system.

SITING

Prior to the mounting of your Sunforce Wind Turbine, you must carefully consider a location.

Things to consider when thinking about your location

1. Distance from any obstacles that will cause turbulence, trees, buildings etc.
2. Distance between turbine and battery bank
3. Any local zoning restrictions
4. Clearance of power lines

In general terms the higher the tower the less obstruction to air flow, leading to a more efficient charge capacity. The minimum recommended tower height is 30 ft or 20 ft above nearby obstructions as shown below.

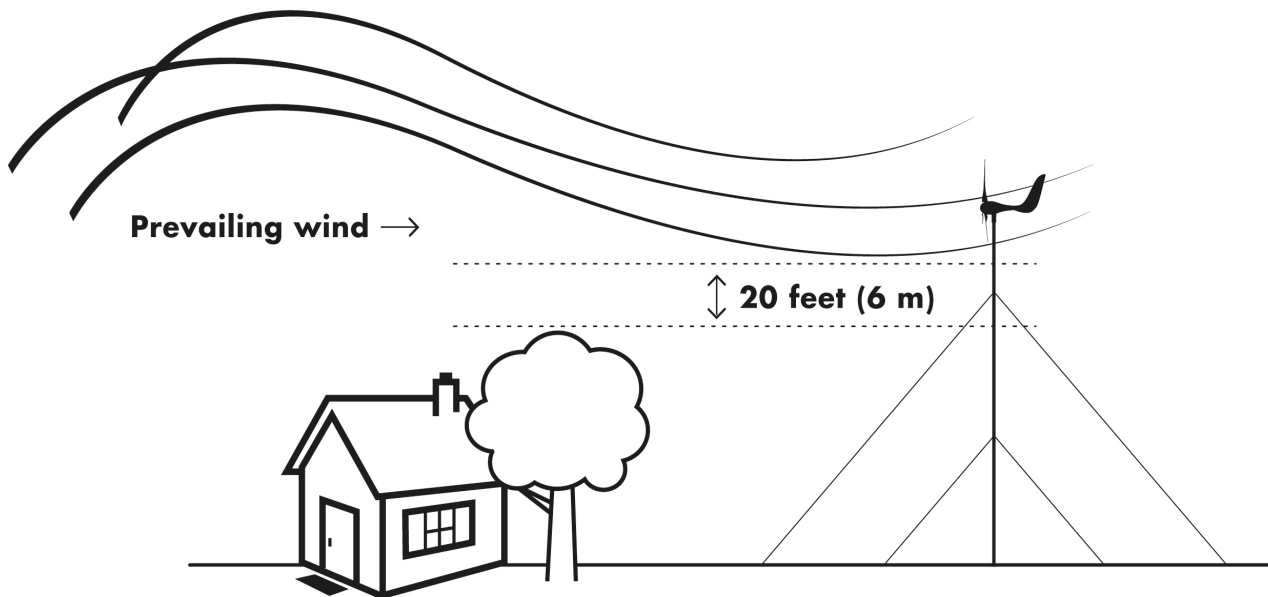

TOWER

Your *Sunforce Products Wind Turbine* is designed to make mounting as simple and straightforward as possible. Should you not wish to purchase the custom Sunforce tower kit feel free to utilize schedule 40 1.5 inch steel tubing. This should be available through your local hardware outlet. Contact your local Sunforce Products dealer for information on tower kits for this turbine!

INSTALLATION

REQUIRED TOOLS

Circuit Breaker (included)
Stop Switch (included)
Plastic Disks (included)
4mm hex key wrench (included)
5mm hex key wrench (included)
8mm hex key wrench (included)

Power cables (not included):
6 sq mm (Europe Wire Gage) stranded or #10 AWG (American Wire Gage) stranded.

Batteries (not included)
Steel Pipe: 1 1/2", Schedule 40 steel pipe (Actual OD 1.875 inches, 48mm) (not included)
Torque wrench
Electrical tape or 1/4" (6-7mm) heat shrink (not included) Wire
strippers (not included)
Wire crimpers (not included)

PRECHECK

Follow these processes shown below to verify if your Sunforce Wind Turbine is working correctly.

Spin rotor shaft slowly with your fingers while at the same time touching the Wind turbines positive and negative wires. With the wires touching the rotor shaft should become more difficult to rotate. With the wires disconnected, it should spin freely. This creates a short.

Connecting the wind turbines wires (RED= Positive, BLACK = Negative) directly to the corresponding posts of the battery 'blinks' the red LED four times. This will show the turbines internal controller is operating correctly.

Should you not see the above mentioned indicators please contact your Sunforce Dealer.

INSTALLATION

Choose a calm day and have someone available to help during the entire installation process.

Caution: THE BLADE EDGES ARE SHARP. PLEASE HANDLE CAREFULLY.

Caution: Do not install the blade assembly until the body is mounted on the tower.

Caution: ALL BATTERIES MUST DISCONNECTED THROUGHOUT THE ENTIRE

INSTALLATION PROCESS!

Run your chosen wire through the pipe and drag the wires close to the batteries (Do not connect to the battery at this point), strip the insulation back from each set of wires

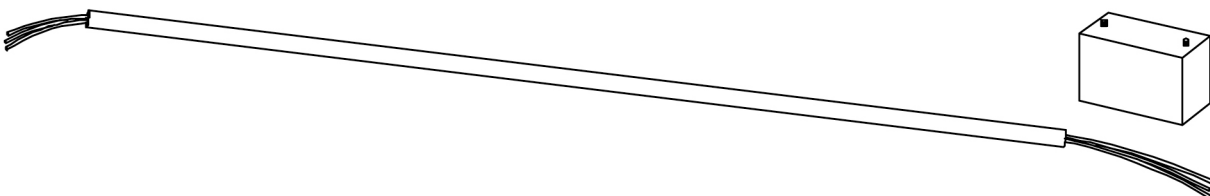

Connect the Wind Generator to the wires and insulate the connections using either heat shrink tubing crimp connects or a high quality electrical tape.

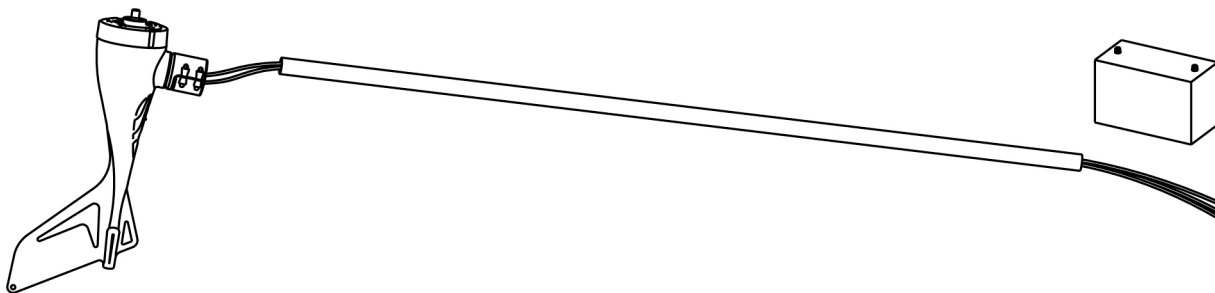

The included rubber gasket helps prevent the bottom of the yaw from contacting the top of the pole. This rubber gasket will assist in reducing the transmission of noise down the tower. Firmly tighten the yaw clamp screws with the 4mm hex key Be sure that it is securely attached to the mounts.

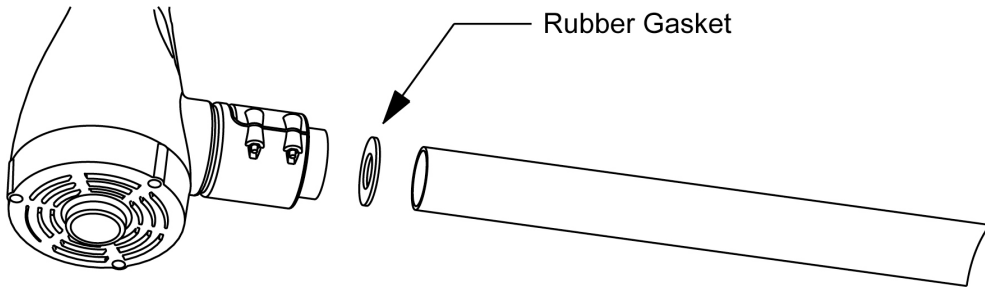

Slide the yaw shaft all the way down over the end of the tower being careful not to pinch the yaw wires. Be sure to leave enough slack in the wires so that if necessary, the Wind Generator can be removed.

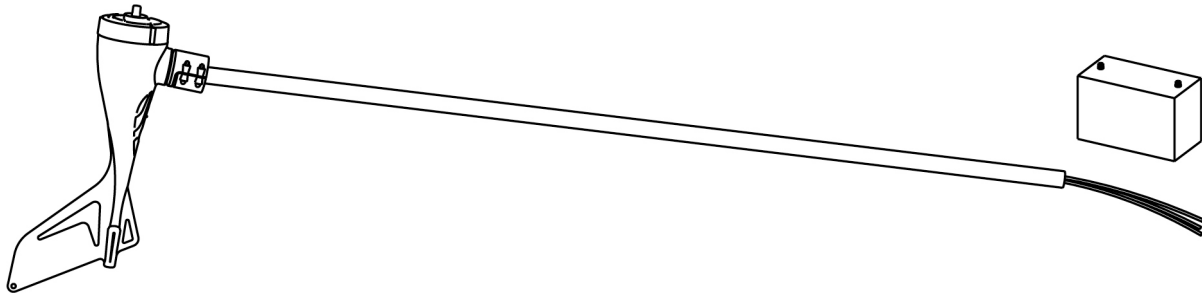

Mark both ends of all the wires with tape to identify which is negative, positive and ground

Wire Color- Codes:
RED = Positive
BLACK = Negative
GREEN = Earth Ground

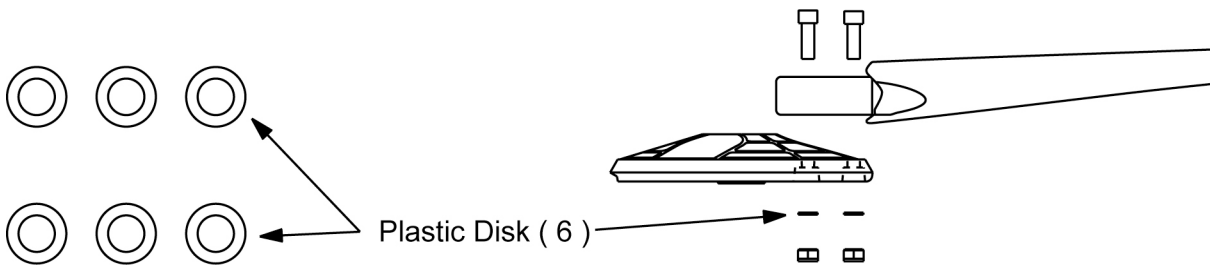

Place one of the blades on the hub socket and insert one of the M6-20 socket head cap screws. Place a plastic disk on the end of the screw, then place a self-locking nut (M6) and tighten it with the 5mm hex key. Repeat this procedure on all three blades.

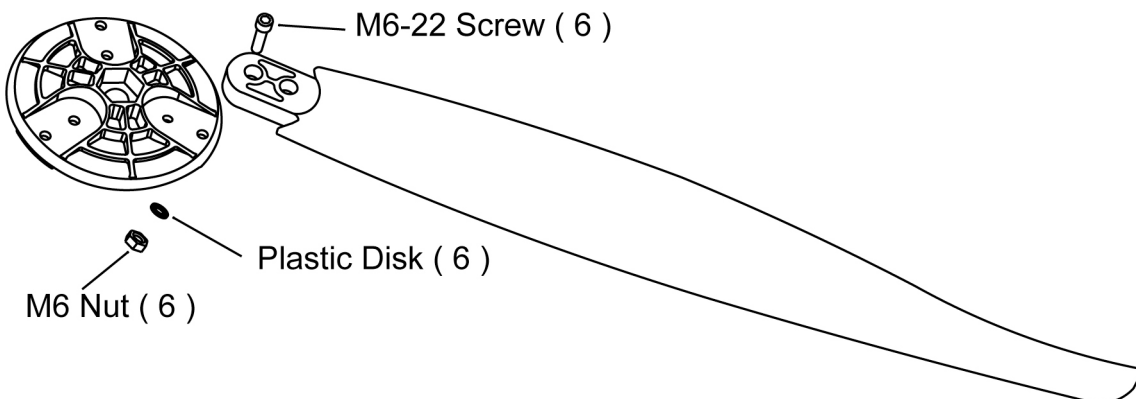

CAUTION: OVER-TORQUE OF SCREWS CAN DAMAGE THE BLADES AND WIND TURBINE

Remove the M16 nut from the rotor shaft. Slide the blades assembly onto the rotor shaft and place the nut on the shaft. **DO NOT** press the rotor shaft into the body.

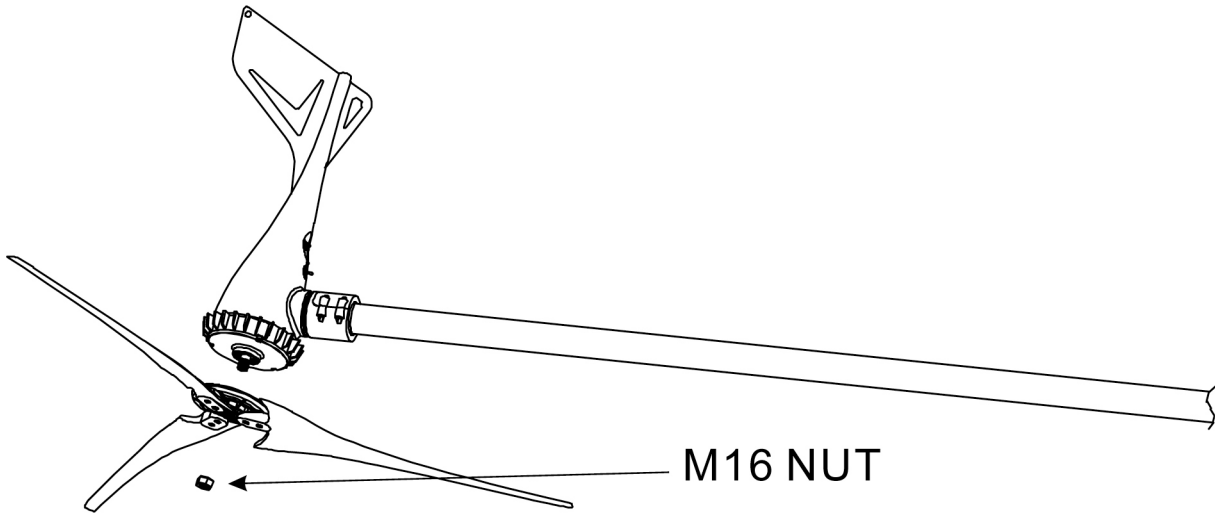

Insert the 8mm hex key into the rotor shaft and thread the nut by spinning the blade assembly. Hold the blade assembly and tighten the M16 nut lightly with the 8mm hex key. Finally, spin the blades slowly to be sure they turn freely.

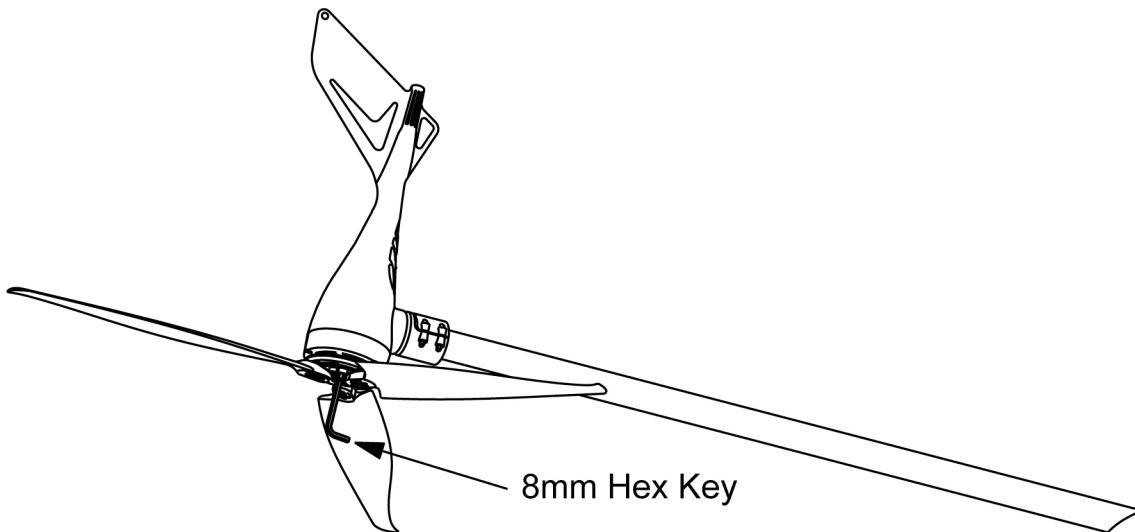

CAUTION: DO NOT OVERSCREW THE M16 NUT THIS WILL PREVENT THE TURBINE FROM SPINNING FREELY

Place the nose cone over the center line of the blades assembly and snap the nose cone into place.

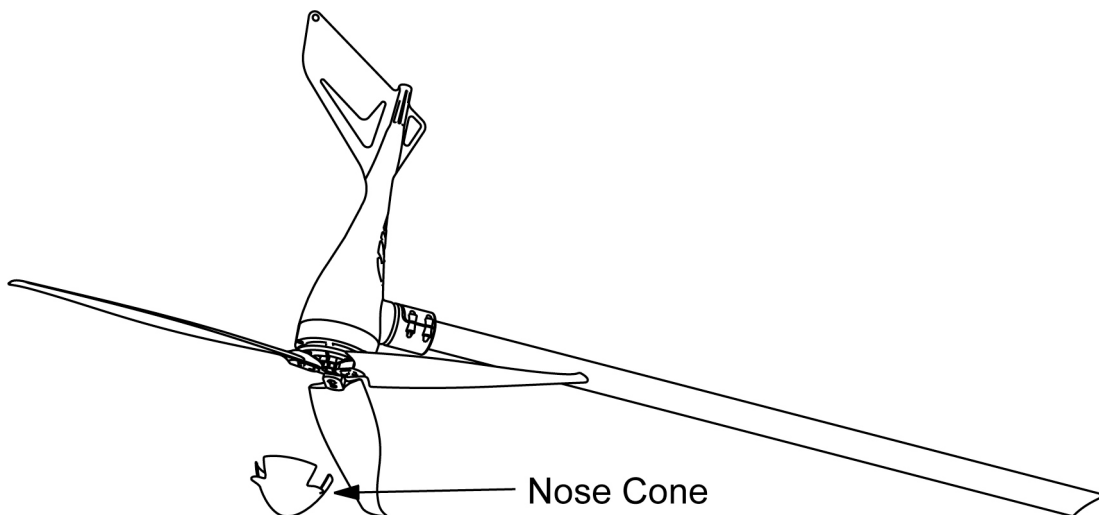

Run all wires close to the batteries. Connect the Circuit Breaker and Stop Switch referring to the diagram in your manual.

CAUTION: DO NOT CONNECT TO THE BATTERIES AT THIS POINT!

ENSURE YOUR TURBINE IS CORRECTLY GROUNDED.

Carefully raise the tower and secure base and/or guy cables.

Make sure the Stop Switch is in the off position, then connect wires to the batteries (Red wire to Positive, Black wire to Negative).

Turn on the Stop Switch, you will see the red LED slowly blink four times to indicate that the controller is running properly.

CONGRATULATIONS! YOU HAVE COMPLETED YOUR WIND TURBINE INSTALLATION

MAINTENANCE:

Your Sunforce Products Wind Turbine has been designed to run for long periods without requiring any maintenance. Performance will be enhanced if you periodically inspect your system. Review the following simple maintenance procedures and implement every six months.

Caution: Do not go near the wind turbine during operation.

- Check blades for superficial damage. Replace blades if damaged. It is important to not use blades that are damaged, as you will lose overall balance, resulting in a decrease in efficiency. Should you notice damage to the blades you must replace all 3. The blades are balanced as sets.
- Check the blade bolts and the hub nut for tightness.
- Check nosecone for cracks and tighten nuts.
- Wipe any excess dirt build-up from the blades.
- Check all electrical connections to make sure they are tight and free from corrosion.
- Check the voltage of your battery bank with a Multi-meter and clean the terminals.
- Sunforce Products suggests replacing the blades every five years for optimal performance.

Trouble shooting

Caution: You may require an extra person to assist with these tests.

- 1) Remove the blade/hub from the turbine. Replace the rotor hub nut on the rotor shaft.
- 2) Quickly spin the rotor shaft manually with your fingers while connecting and disconnecting the red and black wires (turbine must not be connected to batteries).
- 3) With the red and black wires connected to each other, the shaft should be more difficult to turn. When the wires are disconnected it should spin freely.
Should this not be true please contact supplier or Sunforce Products.
- 4) With your Sunforce Wind Turbine connected to your battery bank, use an electric hand drill to spin the rotor shaft.
- 5) Below 500 RPM, the rotor should spin freely without friction.
- 6) At 500 RPM and above, the Wind Turbine should be charging the battery. You should feel resistance on the rotor shaft if the shaft is not rotating; contact your turbine dealer or Sunforce Products. Be aware your battery banks needs to be under fully charged as the Turbine needs to read a charge.

Warranty

Sunforce Products warrants your product to be free from defects in material and/or workmanship for a period of 3 years from original date of purchase. Warranty coverage is extended only to customer (original purchaser). If product proves defective during warranty period, Sunforce Products, at its option will

1. Replace wind turbine with new or refurbished product
2. Correct reported problem

Customers warranty continues to be valid on repaired or replaced product from original warranty date.

Restrictions

This warranty covers defects in manufacturing discovered while using the product as recommended by the manufacturer. The warranty does not apply to a) equipments, materials, or supplies not manufactured by Sunforce Products. b) Product that has been modified or altered other than by Sunforce Products or without prior Sunforce Products approval. c) Has been exposed to winds exceeding 157mph d) Windstorms, lightning and Hail damage e) Repairs performed by other than authorized Sunforce Products support staff. f) All acts of God; misuse, negligence or accidents. g) Tower foundation and wire h) has not been installed, operated, repaired or maintained in accordance with the instructions supplied by manufacturer. Any service identified in the above list or product is found not to have any defect in manufacturers' workmanship or materials the customer will be responsible for the costs of all repairs and expenses incurred by Sunforce Products.

DISCLAIMER

EXCEPT FOR THE EXPRESSED WARRANTY SET FORTH ABOVE, THE MANUFACTURER DISCLAIMS ALL OTHER EXPRESSED AND IMPLIED WARRANTIES, INCLUDING THE IMPLIED WARRANTIES OR FITNESS FOR A PARTICULAR PURPOSE, MERCHANTABILITY AND NON-INFRINGEMENT. NO OTHER WARRANTY, EXPRESSED OR IMPLIED, WHETHER OR NOT SIMILAR IN NATURE TO ANY OTHER WARRANTY PROVIDED HEREIN, SHALL EXIST WITH RESPECT TO THE PRODUCT SOLD UNDER THE PROVISIONS OF THESE TERMS AND CONDITIONS. The manufacturer EXPRESSLY DISCLAIMS ALL LIABILITY FOR BODILY INJURIES OR DEATH THAT MAY OCCUR, DIRECTLY OR INDIRECTLY, BY USE OF THE PRODUCT BY ANY PERSON. ALL OTHER WARRANTIES ARE EXPRESSLY WAIVED BY THE CUSTOMER.

Warranty Claims & Return Policies

To be eligible for service under this warranty, customer must either contact manufacturer either through written request or by telephone to submit a service request for the wind turbine covered by this warranty within specified period (3Years from original purchase) and request a return authorization (RA) number, This RA # must be issued before any product can be returned.

All notifications must include the following information:

- a) Description of alleged defect
- b) How the wind turbine was being used
- c) Serial #
- d) The original purchase date
- e) Name, phone #, address of party requesting warranty

Within 2 to 3 business days Sunforce Products will provide the customer with an RA# and will direct customer to location where the product is to be returned. Once an RA has been issued the customer has 30 days to return the product. Failure to deliver the product within the 30 days results in the RA as no longer being valid and a new RA must be issued. Manufacturer is under no obligation to accept any product that is returned to them without a proper RA #.

LIMITATION OF LIABILITY

UNDER NO CIRCUMSTANCES WILL THE MANUFACTURER OR ITS AFFILIATES OR SUPPLIERS BE LIABLE OR RESPONSIBLE FOR ANY LOSS OF USE, INTERRUPTION OF BUSINESS, LOST PROFITS, LOST DATA, OR INDIRECT, SPECIAL, INCIDENTAL, OR CONSEQUENTIAL DAMAGES OF ANY KIND REGARDLESS OF THE FORM OF ACTION, WHETHER IN CONTRACT, TORT (INCLUDING NEGLIGENCE), STRICT LIABILITY OR OTHERWISE, RESULTING FROM THE DEFECT, REPAIR, REPLACEMENT, SHIPMENT OR OTHERWISE, EVEN IF The manufacturer OR ITS AFFILIATE OR SUPPLIER HAS BEEN ADVISED OF THE POSSIBILITY OF SUCH DAMAGE. (Note: some states and provinces do not allow the exclusion or limitation of incidental or consequential damages, so these limitations may not apply to you.) Neither the manufacturer nor its affiliates or suppliers will be held liable or responsible for any damage or loss to any items or products connected to, powered by or otherwise attached to the hardware. The total cumulative liability to Customer, from all causes of action and all theories of liability, will be limited to and will not exceed the purchase price of the Product paid by Customer. This warranty gives the Customer specific legal rights and the Customer may also have other legal rights that vary from state to state or province to province

For more information or technical support

1-888-478-6435

www.sunforceproducts.com

info@sunforceproducts.com

12VWT120111